

PanelGuard® PG60 - PG80 - PG100 Series Electrical Panel Extension Hardwired Surge

INTRODUCTION

The PG60-80-100 Series is designed to be installed in very close proximity to the power bus of an electric distribution panel or electric panelboard. It can be used with most panels or panelboards in distribution today. The PG60-80-100 Series offers peak surge amperage protection levels of 60 kA to 100 kA per mode. It is designed to be easily mounted above or below the panelboard. Provisions have been made with a reversible cover plate to keep the instructions and indicators in a user friendly position. Standard features include all mode protection, multi-mode LED indicators that show full protection, diminished protection and lost protection for all phases. A form C relay for remote alarm indication, audible trouble alarm with test and silence switch are also standard equipment.

The system is comprised of three sections; outer housing, cover plate and inner module. Each section is engineered to make the installer/service technician's task as easy as possible. A description of each section and the function follows.

Outer Housing - Metal housing measuring 20" wide x 16" high x 6" deep. The outer housing contains the inner housing, connection lugs for each phase, neutral and ground, connections for the form C alarm relay and the audible alarm test and silence switch.

A 5/8" flange on the forward side of the housing has ten (10) threaded holes that are used to attached the cover plate. Four (4) mounting holes are located in the back surface of the housing for mounting. It is suggested that all four (4) fasteners be used to secure the outer housing.

Cover Plate - Metal plate measuring 19 13/16" wide x 15 13/16" high. The cover plate contains ten (10) holes located around the edges that matched the threaded holes in the outer housing and are used to secure the cover plate to the outer housing. The cover plate is reversible and has an identification label on both front and reverse sides. The labels are mirror images of each other and selection of which side to use depends upon the placement of the outer housing. (This process will be explained in the installation section that follows.)

Inner Module - Metal box measuring 13 3/16" wide x 9 3/4" high x 4 15/16" deep including the mounting rails that are part of the module. The inner module is fastened to the outer housing with four (4) bolts through the mounting rails. Module identification and wiring diagram labels are attached to the inner module. The inner module contains all of the surge suppression, noise filtering, fusing, monitoring and reporting components. Copper bus bars and terminal lugs extend from the inner module.

NEC Section 285 requires that a SPD have a fault current rating equal to or greater than the point of installation (switchboard or panelboard). The PG60-80-100 Series is suitable for use on a circuit capable of delivering not more than 200,000 amperes (120/208-3Y, 120/240-2S, 120/240-3HLD, 277/480-3Y models). 480-3D models are rated at 25,000 amperes. Should you require a 480-3D model with a higher fault current rating consider Intermatic PG2500/PG3000/PG3500 Series which are rated at 200 kAIC.

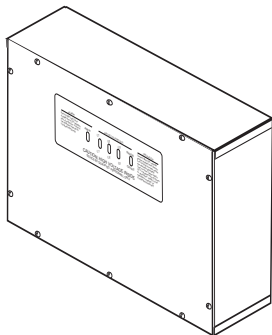

Model # PG100 - 208 - 3Y

PEAK SURGE RATING

PG60	60 kA per Mode
PG80	80 kA per Mode
PG100	100 kA per Mode

SUPPLY VOLTAGE AND CONFIGURATION

240-2S	120/240 Single Phase
208-3Y	120/208 Three Phase Wye
240-3HLD	120/240 Three Phase H. L. Delta
480-3Y	277/480 Three Phase Wye
480-3D	480 Three Phase Delta

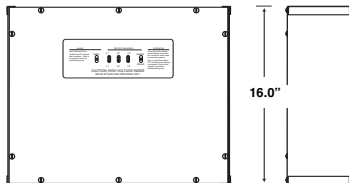

WARNING

BUS BARS AND TERMINAL LUGS ARE ENERGIZED DURING NORMAL OPERATING CONDITIONS. ONLY A QUALIFIED PERSON SHOULD PERFORM SERVICE.

UNPACKING

Open the carton, remove the PG60 - 100 Series unit and examine the outer housing and cover for shipping damage. If damage is observed, notify your supplier.

Remove the cover plate by removing the ten (10) bolts that secure it and examine the inner housing, bus bars, connecting lugs and the alarm device for shipping damage. If damage is observed, notify your supplier.

BEFORE INSTALLATION

1. All electrical wiring and connections should be installed by a qualified electrician. All wiring must comply with the National Electrical Code (NEC) and local codes.
2. This Surge Protection Device (SPD) incorporates a NEMA 12 enclosure.
3. The installation and operation of any Surge Protection Device (SPD) requires proper grounding. A properly sized, insulated grounding conductor is required. The grounding conductor should be the same wire size (gauge) as the phase and neutral conductors used for the SPD. Refer to Table 2 for recommendations.
4. The service entrance and panel grounding configurations must comply with the National Electrical Code and all local codes.
5. Select a location opposite the incoming feed to the panelboard. The SPD must be mounted in an area that provides sufficient working space around the panelboard and SPD cabinet.
6. The collar and/or conduit used to connect this SPD to the panelboard must be sized correctly for the gauge and length of wire required. The length of conduit should allow no more than 1/16" between the edge of the SPD cover plate and the panelboard cover.
6. TEST and verify system voltage to assure proper selection of the Surge Protection Device (SPD) in accordance with the wiring diagrams shown below and on the labels located on the inner module. If the voltage or the number of conductors does not agree with the information supplied with the Surge Protection Device, contact your supplier. If you have questions about the proper use of this unit for your application, contact Intermatic at the numbers listed under TECHNICAL ASSISTANCE on page 5 of this publication.

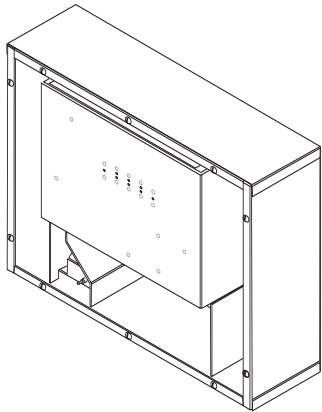

PG60 - PG80 - PG100 Series
with cover plate removed. Unit in position to be installed at the top of panelboard.

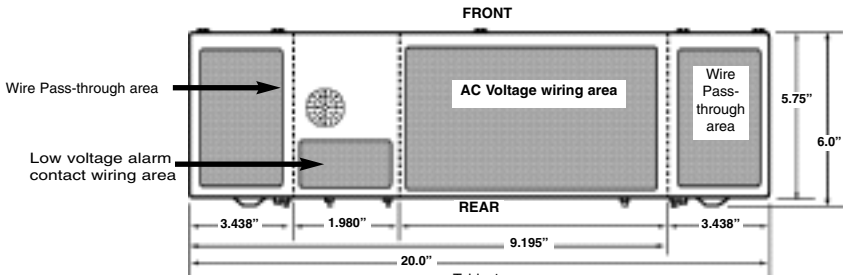

Figure 1
120/240 VAC Single Phase

PG60-240-2S
PG80-240-2S
PG100-240-2S



Line to Line: 240v.; Line to Neutral: 120v.; Line to Ground: 120v.

Figure 2
120/208 VAC Three Phase Wye

PG60-208-3Y
PG80-208-3Y
PG100-208-3Y

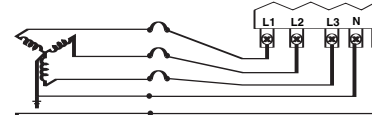

Line to Line: 208v.; Line to Neutral: 120v.; Line to Ground: 120v.

Figure 3
120/240 VAC Three Phase High Leg Delta

PG60-240-3HLD
PG80-240-3HLD
PG100-240-3HLD

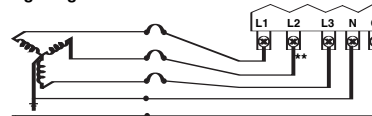

Line to Line: 240v.; Line to Neutral: 120v.; Line to Ground: 120v.

** High Line to Neutral: 208v.; High Line to Ground: 208v.

Figure 4
277/480 VAC Three Phase Wye

PG60-480-3Y
PG80-480-3Y
PG100-480-3Y

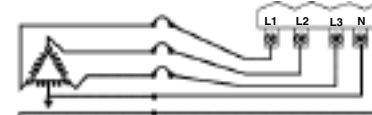

Line to Line: 480v.; Line to Neutral: 277v.; Line to Ground: 277v.

Figure 5
480 VAC Three Phase Delta

PG60-480-3DLL
PG80-480-3DLL
PG100-480-3DLL

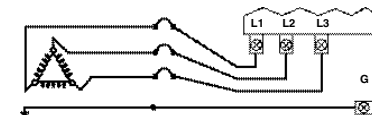

Line to Line: 480v.; Line to Ground: 480v.

INSTALLATION (above panelboard)

1. Turn OFF and LOCK the electric power supply to the panelboard.
2. SELECT the location where the Surge Protection Device (SPD) will be mounted, above or below the electric panel. Position the SPD adjacent to the electric panel with the bus bars pointed toward the panel. NOTE: If the SPD is mounted below the electric panel, the labels on the inner housing will be inverted. Refer to INVERTED INSTALLATION section below for information regarding the inverted installation. Align the SPD to allow 1/16" between the SPD cover plate and the cover of the panelboard. The SPD should be secured to a flat vertical surface that can support the weight of the device.
3. Temporarily fasten the SPD to the vertical surface and mark the location where a hole for the collar or conduit will enter. Refer to Table 1 for acceptable locations on the bottom of the Outer Housing that can be drilled for wire entry. Note that wiring for the remote monitoring relay enters separate from the AC power leads. Remove the SPD unit and drill a hole of sufficient size to accept the collar or conduit connector. Attach the collar or connector to the SPD outer cabinet and mount the unit with the collar or connector inserted into the knockout in the panelboard.
4. Use the proper gauge wire to connect each of the lugs on the SPD to the appropriate points on the electric panel. See Table 2 for recommended wire and breaker sizes. Use of a dedicated circuit breaker is optional since the SPD has integral overcurrent fusing. The SPD can be connected through feed-thru lugs on a panelboard. The SPD can be connected through a breaker or direct tapped for Switchboard installations. Select a position for the connection that results in the shortest lead lengths between the SPD and the power bus. Leads should be kept as short as possible to insure optimum operation. Measure and cut all leads to proper length. Strip the ends of each lead 9/16" for the SPD terminal lugs and to proper length for the breaker used. Connect the wire leads to the lugs on the bus bars of the SPD. Torque the lugs 35 to 50 inch pounds per UL 486 torque tightening requirements.

NOTE: For safety, observe proper wire marking conventions; BLACK for HOT, RED for HOT HIGH LEG, WHITE for NEUTRAL, GREEN for GROUND.

5. Route the wire lead bundle through the collar or connector into the electric panel.
 6. Connect the GROUND (green) lead to the ground bus in electric panel.
 7. If used, connect the NEUTRAL (white) to the neutral bus in the electric panel. If installing at a main electrical panel, the neutral and ground leads could terminate at a common bus bar in the panel.
 8. Connect the phase leads to the appropriate breaker in the electric panel.
- NOTE: For HIGH LEG DELTA, make certain that the high leg is connected to the center bus bar position in the SPD. (Refer to Figure 3)**
9. Connect wires to the alarm relay leads if used. Alarm wires should be routed through a hole in the outer housing that is separate from the power leads. If the alarm relay is not used, leave the wires in the low voltage section, they will have no power and do not need to be capped. Refer to the alarm wiring drawings on page 3 or on the wiring label on the inner housing for wire designation.
 10. CHECK all connections for correct torque.

SUGGESTED WIRE and BREAKER SIZES

Use the following table as a guideline for the PG60, PG80 and PG100 Surge Protection Devices. All models have integral overcurrent fusing and the use of a dedicated circuit breaker is optional. Lugs accept wire sizes from 10 AWG to 2 AWG. Keep all leads as short and straight as possible, avoiding sharp 90 degree bends. Increase wire size when lead length is extended.

10 AWG	30 AMP	8 AWG	40 AMP	6 AWG	50 AMP	4 AWG	60 AMP	2 AWG	80 AMP
--------	--------	-------	--------	-------	--------	-------	--------	-------	--------

Table 2

INVERTED INSTALLATION (under panelboard)

- Turn OFF and LOCK the electric power supply to the panelboard.
- SELECT the location where the Surge Protection Device (SPD) will be mounted below the electric panel. Position the SPD adjacent to the electric panel with the bus bars pointed toward the panel. NOTE: The labels on the inner housing will be inverted. Align the SPD to allow 1/16" between the SPD cover Plate and the cover of the panelboard. The SPD should be secured to a flat vertical surface that can support the weight of the device.
- Temporarily fasten the SPD to the vertical surface and mark the location where a hole for the collar or conduit will enter. Refer to Table 1 for acceptable locations on the bottom of the Outer Housing that can be drilled for wire entry. Note that wiring for the remote monitoring relay enters separate from the AC power leads. Remove the SPD unit and drill a hole of sufficient size to accept the collar or conduit connector. Refer to Table 2 for suggested collar or conduit sizes. Attach the collar or connector to the SPD outer cabinet and mount the unit with the collar or connector inserted into the knockout in the panelboard.
- Use the proper gauge wire to connect each of the lugs on the SPD to the appropriate points on the electric panel. See Table 2 for recommended wire and breaker sizes. Use of a dedicated circuit breaker is optional since the SPD has integral overcurrent fusing. The SPD can be connected through a breaker or direct tapped for Switchboard installations. Select a position for the connection that results in the shortest lead lengths between the SPD and the power bus. Leads should be kept as short as possible to insure optimum operation. Measure and cut all leads to proper length. Strip the ends of each lead 9/16" for the SPD terminal lugs and to proper length for the breaker used. Connect the wire leads to the lugs on the bus bars of the SPD. Torque the lugs 35 to 50 inch pounds per UL 486 torque tightening requirements.

NOTE: For safety, observe proper wire marking conventions; BLACK for HOT, RED for HOT HIGH LEG, WHITE for NEUTRAL, GREEN for GROUND.

- Route the wire lead bundle through the collar or connector into the electric panel.
- Connect the GROUND (green) lead to the ground bus in electric panel.
- If used, connect the NEUTRAL (white) to the neutral bus in the electric panel. If installing at a main electrical panel, the neutral and ground leads could terminate at a common bus bar in the panel.
- Connect the phase leads to the appropriate breaker in the electric panel.

NOTE: For HIGH LEG DELTA, make certain that the high leg is connected to the center bus bar position in the SPD. (Refer to Figure 3)

- Connect wires to the alarm relay leads if used. Alarm wires should be routed through a hole in the outer housing that is separate from the power leads. If the alarm relay is not used, leave the wires in the low voltage section, they will have no power and do not need to be capped. Refer to the alarm wiring drawings on page 3 or on the wiring label on the inner housing for wire designation.
- CHECK all connections for correct torque.

ALARM RELAY CONNECTIONS

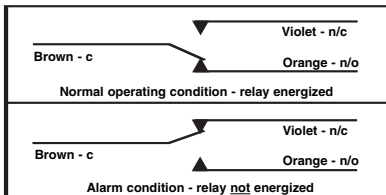

Figure 6

ALARM RELAY SPECIFICATIONS

- Relay: Single pole double throw.
 Power Rating: 120 VAC - 500 mA
 24 VAC - 1 A.
- Operation: Energized during normal conditions.
 De-energized during alarm conditions or loss of power.

ALARM CONDITIONS

Alarm sounding and relay in "alarm state"

- The audible alarm will sound and the alarm relay output will reverse state upon the loss of one or more protection components.
- CAUTION:** The following steps should be performed only by qualified personnel. Remove the ten (10) bolts holding the cover plate in place.
 - Move the Alarm Switch to the SILENCE position. The local audible alarm should silence but the alarm relay output should remain in the alarm condition until the unit is returned to normal operating condition.
 - Verify that the proper voltage is present at each of the terminal lugs. **CAUTION: LINE VOLTAGE MAY BE PRESENT AT THE TERMINAL LUGS.**
 - Turn the breaker OFF and then ON to reset the SPD.
 - If the alarm condition will not clear upon reset and the line voltages are present and are of the correct value, contact Intermatic TECHNICAL ASSISTANCE at the number given on page 5 of this publication.

Alarm not sounding but relay in "alarm state"

- The alarm relay output will change state but the audible alarm will not sound under the following conditions:
 - Loss of power to the PG Series unit.
 - The circuit breaker in the electric panel that is feeding the SPD is turned to the OFF position or tripped.
 - A fault exists in the remote monitor system.
- Check for PROTECTION STATUS indicator light illumination. If all of the Line indicator lights are ON and the Alarm indicator light is OFF, consult directions for trouble shooting the remote monitoring system.

FINAL CHECKOUT PROCEDURE

1. CHECK all connections for correct location and torque.
2. Make sure that the electrical panel and the SPD are clear of all tools, metal parts and personnel.
3. Turn power ON to the electrical panel.
4. Place Alarm Switch in the NORMAL position.
5. Turn the power ON to the SPD.
6. Check all PROTECTION STATUS Line indicator lights for proper illumination.
PROTECTION MODE indicators ON.
ALARM indicator OFF.
7. Check output continuity for the Alarm Relay if used.
(a) Common to Normally Open = greater than 10 M ohms, (b) Common to Normally Closed = 0 ohms.
8. The Audible Alarm should be silent.
9. Place Alarm Switch in SILENCE position: Audible alarm should sound. Return Alarm Switch to normal position.
10. Place Alarm Switch in TEST position. Audible alarm should sound, the Red Alarm Indicator LED should be ON and the alarm relay outputs should reverse state. Return the switch to the NORMAL position.

OPERATION

1. The ALARM SWITCH should be in the NORMAL position for standard operating conditions.
2. The COVER PLATE must be in position with all bolts secured to prevent access by unauthorized personnel.
3. The PROTECTION MODE indicator lights should be ON.
4. The ALARM indicator light should be OFF.
10. Periodic functional checks of the system as required by local codes or procedures are conducted by performing steps 9 and 10 of the FINAL CHECKOUT PROCEDURE.

COVER PLATE INSTALLATION

The cover plate has labels on the front and back. One side has the labels positioned for use when the SPD is located at the top of the electrical panel. The second side of the cover plate is used when the SPD is positioned at the bottom of the electric panel. MAKE SURE THAT THE PROPER SIDE IS PLACED FORWARD AND ALL INDICATOR LIGHTS ARE VISIBLE.

SPD mounted above the Panelboard

1. Position the cover plate on the face of the outer housing so that the mounting holes align with the threaded holes and the indicator light positions in the label align with the indicator lights in the inner module.

NOTE: In this application, the label with the LED indicators will be at the top of the cover plate.

SPD mounted under the Panelboard

1. Position the cover plate on the face of the outer housing so that the mounting holes align with the threaded holes and the indicator light positions in the label align with the indicator lights in the inner module.

NOTE: In this application, the label with the LED indicators will be at the bottom of the cover plate.

TECHNICAL ASSISTANCE

For application or technical assistance contact Intermatic at 1-800-391-4555 or on the web at www.intermatic.com.

TYPICAL INSTALLATIONS

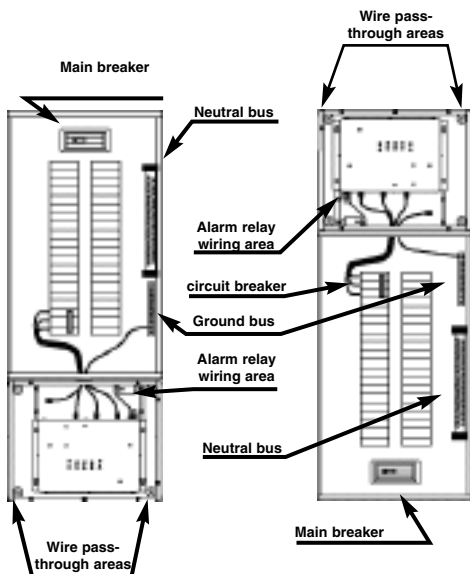

Figure 6

TEN YEAR LIMITED PRODUCT WARRANTY

For

Intermatic PG60-80-100 Series SURGE PROTECTION DEVICES

(1) What Is Covered By This Limited Warranty

Repair or Replacement of Product

Intermatic Incorporated ("Intermatic") warrants to the original purchaser only, the Intermatic model PG60-240-2S, PG60-208-3Y, PG60-240-3HLD, PG60-480-3Y, PG60-480-3DLL, PG80-240-2S, PG80-208-3Y, PG80-240-3HLD, PG80-480-3Y, PG80-480-3DLL, PG100-240-2S, PG100-208-3Y, PG100-240-3HLD, PG100-480-3Y and PG100-480-3DLL, PanelGuard® Surge Protection Devices (each a "Product") shall be free from defects in material or workmanship for a period of ten years (120 months) from date of purchase or 126 months from date of manufacture. If the purchaser discovers a defect in material or workmanship, the purchaser must promptly submit a warranty claim. Upon a determination by Intermatic that the Product is defective, Intermatic shall correct any defect in material or workmanship by, at Intermatic's option, either repairing or replacing the defective Product. Any repair, including both parts and labor, shall be at Intermatic's expense. The foregoing remedies are the purchaser's exclusive remedies for a breach of warranty.

For purposes of this Limited Warranty, a Power Transient shall mean over-voltage resulting from momentary voltage spikes or surges on an AC power line of magnitude that the Product, according to its specifications, is designed to stop before such spikes or surges affect downstream equipment.

The Product must be installed in the appropriate application in complete accordance with the installation instructions. All building wiring and other connections to the Product must conform to all applicable national, state and local electrical codes; the Product must not be opened, modified, exposed to extreme heat or cold, submerged or subjected to abnormal use or service. All products must be used in accordance with the instructions provided with the Product and the purchaser shall be solely responsible for selecting a Product model with specifications appropriate for the equipment to be protected. Intermatic shall determine, in its sole discretion, whether any Product returned by a purchaser has been used in accordance with its instructions, is an appropriate model for the purchaser's use thereof, and whether the Product is defective.

(2) What Is Not Covered By This Warranty

Intermatic does not warrant (a) defects in the Product or damage to any equipment caused by the failure to properly install the Product; (b) damage caused by use of the Product for purposes other than those for which it was designed; (c) damage caused by disaster such as fire, flood and wind; (d) damage caused by unauthorized attachments or modification of the Product; (e) damage to the Product occurring during shipment; (f) damage caused by electrical disturbances exceeding published product specifications or (g) damage to the Product caused by any other abuse or misuse by the purchaser.

(3) Disclaimer of Warranty

THE FOREGOING WARRANTIES ARE IN LIEU OF ALL OTHER EXPRESSED WARRANTIES. TO THE EXTENT ALLOWED BY LAW, ANY IMPLIED WARRANTIES OF MERCHANTABILITY OR FITNESS FOR A PARTICULAR PURPOSE ARE LIMITED IN DURATION TO THE DURATION OF THIS LIMITED WARRANTY.

(4) Limitation of Remedies

IN NO CASE SHALL INTERMATIC BE LIABLE FOR ANY SPECIAL, INCIDENTAL, OR CONSEQUENTIAL DAMAGES BASED UPON BREACH OF WARRANTY, BREACH OF CONTRACT, NEGLIGENCE, STRICT TORT, OR ANY OTHER LEGAL THEORY. SUCH EXCLUDED DAMAGES INCLUDE, BUT ARE NOT LIMITED TO, DAMAGE TO SOFTWARE, LOSS OF DATA, LOSS OF PROFITS, LOSS OF SAVINGS OR REVENUE, LOSS OF USE OF THE PRODUCT OR ANY ASSOCIATED EQUIPMENT, COST OF CAPITAL, COST OF ANY SUBSTITUTE EQUIPMENT, FACILITIES OR SERVICES, DOWNTIME, THE CLAIMS OF THIRD PARTIES INCLUDING CUSTOMERS, DAMAGE TO PROPERTY AND PERSONAL INJURY. SOME STATES DO NOT ALLOW LIMITS ON WARRANTIES OR ON REMEDIES FOR BREACH IN CERTAIN TRANSACTIONS. IN SUCH STATES, THE LIMITS IN THIS PARAGRAPH AND IN PARAGRAPH (3) MAY NOT APPLY.

(5) Time Limit for Bringing Suit

No action arising out of any claimed breach of warranty may be brought more than one year after the cause of action has occurred.

(6) No Other Warranties

Unless modified in writing signed by both parties, this agreement is understood to be the complete and exclusive agreement between the parties, suspending all prior agreements, oral or written, and all other communications between the parties relating to the subject matter of this agreement. No employee of Intermatic or any other party is authorized to make any warranty in addition to those made in this agreement.

INTERMATIC INCORPORATED

SPRING GROVE, ILLINOIS

<http://www.intermatic.com>