



## Installation & Operating Instructions

# LightMaster™ PC/LM Series

Light Sensor Control

### **⚠ WARNING** Risk of Fire or Electric Shock

- Disconnect power at the circuit breaker(s) or disconnect switch(es) before installing or servicing.
- More than one circuit breaker or disconnect switch may be required to de-energize the equipment before servicing.
- Use #22 - #12 AWG wire - COPPER conductors ONLY. Rated 90°C Min.
- Installation and/or wiring must be in accordance with national and local electrical code requirements.
- For outdoor locations, raintight, or wet locations, conduit hubs that comply with requirements of the UL514B (standard for fitting for conduit and outlet boxes) are to be used.
- Photoelectric sensor shall be directly mounted to enclosure using standard conduit connection means.
- When photoelectric sensor is mounted in a remote location, wiring shall be routed separately from Class 1 wiring.
- When photoelectric sensor is mounted in a remote location and routed with Class 1 wiring, the wiring insulation shall be rated for the minimum voltage of the Class 1 wiring.
- KEEP DOOR CLOSED AT ALL TIMES when not servicing.

### **NOTICE**

- The warranty will be void if the wrong voltage is applied. Connect the wires in accordance with the wiring diagram.

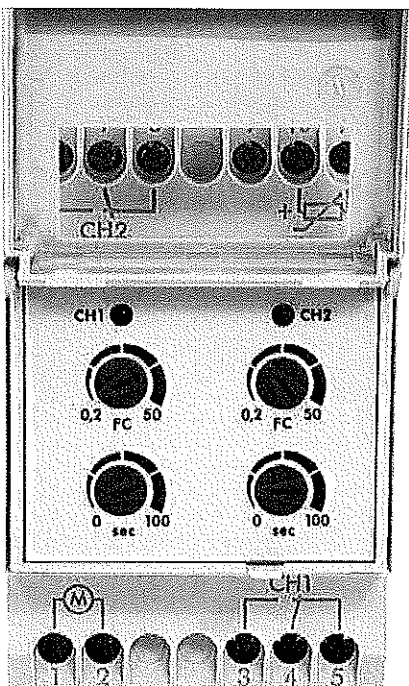

### DESCRIPTION

The LightMaster PC Series Lighting Control system independently controls one or two circuits based on the amount of natural light in an area. When the detected light drops below the configured foot-candle setting, LightMaster turns circuits ON. When natural light rises above the setting, LightMaster turns circuits OFF. Each circuit has adjustable time delay dials from 0 to 100 seconds to prevent unwanted switching caused by headlights, lightning, and other conditions. LightMaster can be used with LS2 high-range opaque sensors for typical outdoor dusk-to-dawn applications or with LS1 clear sensors for indirect light applications.

### MOUNTING THE LightMaster MODULE

There are multiple mounting options for the LightMaster module. Follow the applicable guidelines for the appropriate mounting method for your facility.

- **Surface Mount in a control panel or enclosure with a standard DIN rail**
  - Place the top two protruding guides located on the back of the unit over the top lip of the DIN Rail and snap into place.
- **Mount as a Stand alone unit**
  - Mount the LightMaster in a TYPE 3R indoor/outdoor enclosure.

NOTE: Also available: LM2 Series system with included TYPE 3R enclosure.

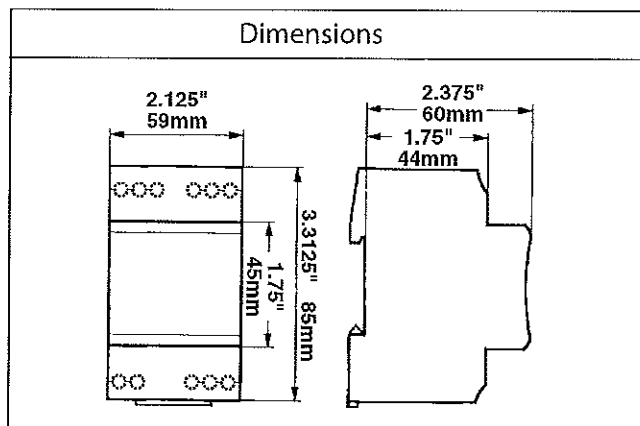

### MOUNTING THE LightMaster SENSORS:

Follow these guidelines to mount the LS1 or LS2 sensor.

- If sensor is mounted directly to enclosure of controller, use standard conduit connection means.
- If sensor is mounted remotely from controller, either route sensor wiring separately from class 1 wiring or use wiring for sensor rated for the minimum voltage of adjacent class 1 wiring.
- The light level sensor can be mounted indoors or outdoors.
- It must be mounted vertically with the wires facing down.
- The wiring length should not exceed 330 feet and should not be run in close proximity to current carrying wires.
- If you are using the sensor for dusk/dawn sensing, position the sensor with the arrow facing a wall.
- If you are using the sensor to control interior lighting, awnings, or shades, position the sensor with the arrow facing away from the building towards the sunlight.
- Be sure to position the sensor so unwanted lighting, such as car headlights, will not influence it.

**TECHNICAL DATA:**

Input Voltage: 120 VAC, 60 Hz  
 Resistive Rating: 10 Amp, 120-277 VAC per circuit  
 Ballast Rating: 8A @ 120-277 VAC  
 Output Relay: SPDT "isolated" contacts for each circuit

Power Consumption: 2.5 VA

**Humidity Range:**  
 Control Unit 0 to 95% RH non-condensing  
 Sensor 0 to 100% RH

Weight: 8.5 oz  
 Mounting: Surface & DIN rail  
 (TYPE R enclosures available)

Light Sensitivity Adj.: .2 to 50 Foot Candles w/LS-1 sensor  
 50 to 1000 F.C. w/LS-2 sensor

Time Delay Before Switching: Adjustable 0 to 100 seconds

**WIRING INSTALLATION CHECKLIST**

- Make sure the control has its own independent circuit for the power supply.
- Be sure the power supply to the unit is from a circuit different from the load.
- **INDUCTIVE LOADS** should have a suitable VARISTOR and RC network across the supply terminals to reduce voltage spikes.
- **DC INDUCTIVE LOADS** should have a diode across their terminals to eliminate back EMF of the inductor.
- In areas with frequent lightning occurrences, a surge suppressor should be installed.

**WIRING INSTALLATION**

Be sure to only connect the supply voltage designated on the unit.

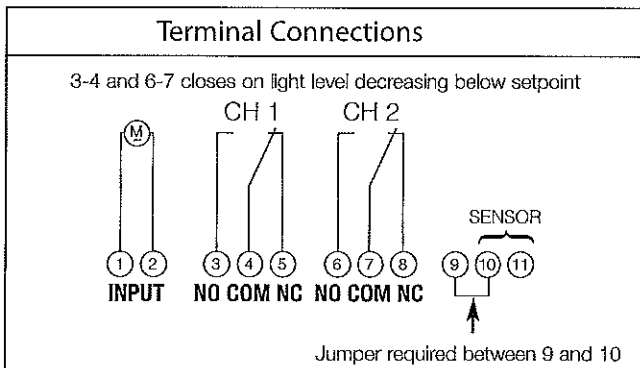

Follow this procedure to complete the wiring for the LightMaster.

1. Connect the power wires to terminals 1 and 2.
2. Connect power wire to switch common wire.
3. Connect the wire from the switch's normally open contact(s) to the load(s) or contactor coil(s) that are going to be controlled.
4. Mount the sensor to a junction box within 330 feet of the control.
5. Connect the sensor wires to terminals 10 and 11.
6. Jumper terminals 9 and 10.

**Wiring Multiple PC2s to One Sensor**

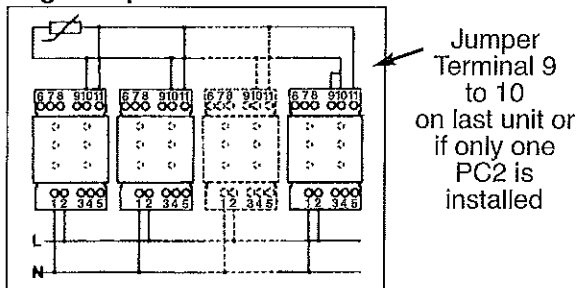

7. Note: Up to 10 modules may be wired to one sensor.

**ADJUSTING LIGHT LEVEL and TIME DELAY CONTROLS**

The amount of natural light present in an area can affect the way the sensor performs. Be sure to account for the light when configuring the LightMaster settings. If you have a 2-channel unit, be sure to adjust both channel controls to the applicable settings.

1. Turn the light-level control(s) to the desired setting(s). See the figure below for an illustration of the foot-candle levels at various control settings.

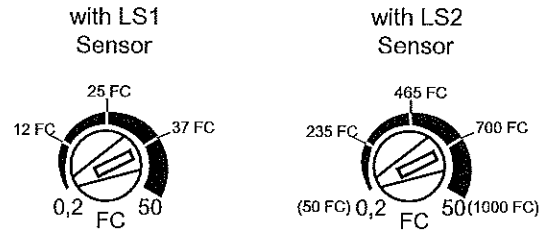

2. Turn the time delay control(s) to the desired delay duration. See figure below for an illustration of the seconds of delay at various control settings. The delay begins when the red LED changes (on or off).

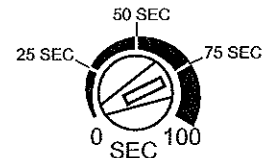

**STATUS INDICATION**

A red LED for the corresponding circuit illuminates when the natural light level is below the configured foot-candle level.

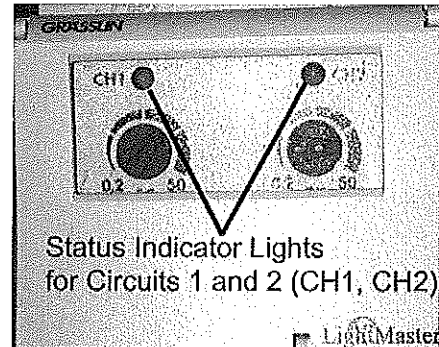

**ONE YEAR LIMITED WARRANTY**

If within the warranty period specified, this product fails due to a defect in material or workmanship, Intermatic Incorporated will repair or replace it, at its sole option, free of charge. This warranty is extended to the original household purchaser only and is not transferable. This warranty does not apply to: (a) damage to units caused by accident, dropping or abuse in handling, acts of God or any negligent use; (b) units which have been subject to unauthorized repair, opened, taken apart or otherwise modified; (c) units not used in accordance with instructions; (d) damages exceeding the cost of the product; (e) sealed lamps and/or lamp bulbs, LED's and batteries; (f) the finish on any portion of the product, such as surface and/or weathering, as this is considered normal wear and tear; (g) transit damage, initial installation costs, removal costs, or reinstallation costs.

INTERMATIC INCORPORATED WILL NOT BE LIABLE FOR INCIDENTAL OR CONSEQUENTIAL DAMAGES. SOME STATES DO NOT ALLOW THE EXCLUSION OR LIMITATION OF INCIDENTAL OR CONSEQUENTIAL DAMAGES, SO THE ABOVE LIMITATION OR EXCLUSION MAY NOT APPLY TO YOU. THIS WARRANTY IS IN LIEU OF ALL OTHER EXPRESS OR IMPLIED WARRANTIES. ALL IMPLIED WARRANTIES, INCLUDING THE WARRANTY OF MERCHANTABILITY AND THE WARRANTY OF FITNESS FOR A PARTICULAR PURPOSE, ARE HEREBY MODIFIED TO EXIST ONLY AS CONTAINED IN THIS LIMITED WARRANTY, AND SHALL BE OF THE SAME DURATION AS THE WARRANTY PERIOD STATED ABOVE. SOME STATES DO NOT ALLOW LIMITATIONS ON THE DURATION OF AN IMPLIED WARRANTY, SO THE ABOVE LIMITATION MAY NOT APPLY TO YOU.

This warranty service is available by either (a) returning the product to the dealer from whom the unit was purchased or (b) completing a warranty claim online at [www.intermatic.com](http://www.intermatic.com). This warranty is made by: Intermatic Incorporated, Customer Service 7777 Winn Rd., Spring Grove, Illinois 60081-9698. For warranty service go to: <http://www.intermatic.com> or call 815-675-7000.

**INTERMATIC INCORPORATED**  
 Spring Grove, Illinois 60081-9698 U.S.A.