



Model LZ6001

Solar Garden Lights

READ INSTRUCTIONS BEFORE USING THIS PRODUCT

Enjoying Your New Solar Lights

You have purchased the top performing solar landscape lights available. Malibu SolarSelect landscape lights feature a Summer/Winter adjustment switch located on the back of the solar panel.

- High setting delivers the brightest output and will deliver approximately 1 hour of on-time for every hour of full sun. Use this setting from Spring into early Fall.
- Low setting lengthens on-time during late Fall through early Spring. During this time most locations receive fewer hours of full sun per day.

Your new solar lights use a solar panel to convert the power of the sun into electricity. The included rechargeable batteries store this energy to power the bright LED bulbs.

The amount of on-time will be dependent on the amount of full sunlight your lights receive the previous day. In general, if your lights receive 8 hours of full sun, you can expect 6 – 8 hours of on-time.

Malibu Solar lights will turn on automatically every evening as the sun sets. It is important to note that strong ambient lighting (porch/street lights) can prevent your lights from operating properly. If this occurs, eliminate or reduce the ambient light source or place the fixture in a darker location.

Assembly

1. **IMPORTANT:** Remove battery insulator strip from battery compartment (Figure 1). Your lights will not operate or charge if not removed.

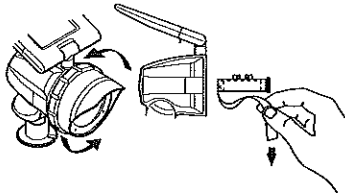

Figure 1

2. Adjust Winter/Summer switch — Set to High (H) for brighter illumination in summer when charging hours are longer, set to Low (L) in winter to conserve power (Figure 2).

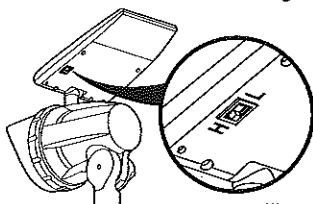

Figure 2

3. Adjust solar panel angle — Angle up to 90° and rotate up to 360° for maximum sun exposure to panel (Figure 3).

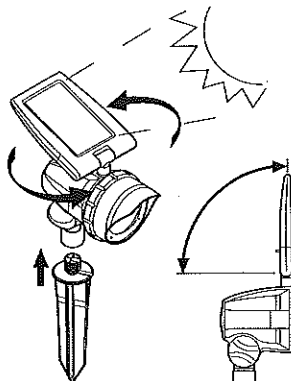

Figure 3

4. Push (or screw) on ground stake.

Parts List for Each Light

1. Light with LED and installed AA rechargeable batteries
2. Ground stake

Order missing, damaged, or defective parts for new purchases only at:

parts.intermatic.com

or

Call 800-492-2289

**8:00 am – 4:30 pm, Monday – Friday
Central Standard Time**

IMPORTANT: Please have product model number available before calling.

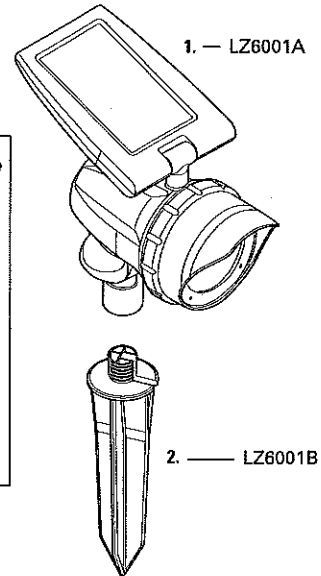

Figure 4

Installation

1. Locate and mark where you intend to install your Solar Landscape lights.
2. Hold the fixture by gripping the sides and push stake firmly into the ground (Figure 5).

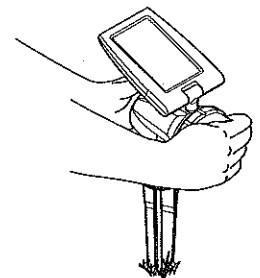

Figure 5

Note

You may damage your solar light if pressure is applied to the top of the light. This will damage the solar cell and electronics.

3. If the ground is too hard, loosen the soil with water or dig a small pilot hole (Figure 6).
4. After light is in place, firmly compact soil so light does not shift.

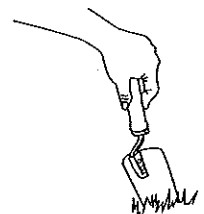

Figure 6

Battery Replacement

The rechargeable batteries provided are designed to recharge up to 1000 times in normal use. Therefore the batteries will need to be replaced after 2 – 3 years. Rechargeable batteries are available at most retail stores.

Recommended: (3) Malibu replacement Nickel Metal Hydride (NMH) LZ15004 or equivalent (1500mA capacity or greater).

1. Remove front lens from fixture (Figure 7).

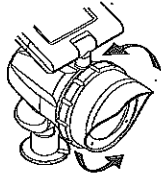

Figure 7

2. Remove and replace batteries (it is helpful to use a small screwdriver to lift the end of the batteries from the compartment) (Figure 8).

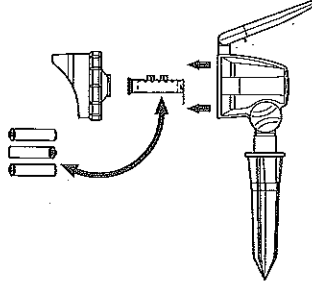

Figure 8

3. Replace the front lens on the fixture (Figure 9).
4. The batteries will need at least one cycle of sun recharging to operate normally.

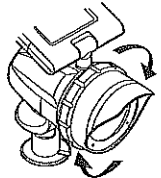

Figure 9



Batteries must be recycled or disposed of properly.

Maintenance

Your solar lights require very little maintenance.

- Keep the solar cell at the tops of the fixtures clean and free of debris.
- Replace the rechargeable batteries every 2 – 3 years.

Seasonal and Weather Variations

- Your lights will naturally receive fewer hours of sunlight during the winter. Consequently your lights will not operate as long during this season (Figure 10).
- Cloudy days will affect your lights' ability to recharge the batteries, therefore your light on-time may be significantly less than after a day of full sunshine.

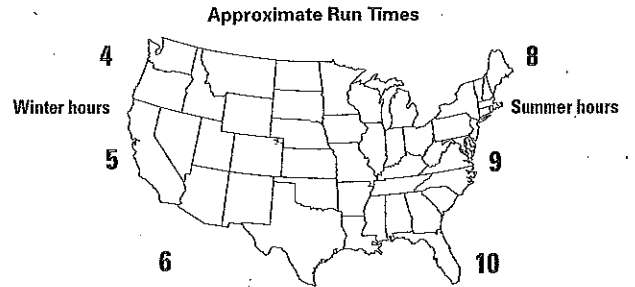

Figure 10

NOTICE

- Do not submerge in water, the product can be damaged.
- Do not repair or modify this product.
- This product is not a toy and must not be operated by children.

Troubleshooting Guide

Observed Problem	Possible Cause	What to Do
My lights do not turn on in the evening or only light for a short time.	Not enough sunlight — as a general rule, one hour of full sun equates to 45 minutes of on-time at night.	Make sure your lights are positioned to receive full sunlight. Shade from trees, shrubs or overhangs often block enough light to substantially reduce light on-time.
	Artificial lights can keep your lights from turning on at night.	Make sure your lights are located 6 – 8 feet away from bright light sources (porch, street lights).
	Batteries may be weak or near end of normal service life.	Replace batteries.

LIMITED TWO-YEAR WARRANTY

If within two (2) years from the date of purchase, this product fails due to a defect in material or workmanship, Intermatic Incorporated will repair or replace it, at its sole option, free of charge. This warranty is extended to the original household purchaser only and is not transferable. This warranty does not apply to: (a) damage to units caused by accident, dropping or abuse in handling, acts of God or any negligent use; (b) units which have been subject to unauthorized repair, opened, taken apart or otherwise modified; (c) units not used in accordance with instructions; (d) damages exceeding the cost of the product; (e) sealed lamps and/or lamp bulbs, LED's and batteries; (f) the finish on any portion of the product, such as surface and/or weathering, as this is considered normal wear and tear; (g) transit damage, initial installation costs, removal costs, or reinstallation costs.

INTERMATIC INCORPORATED WILL NOT BE LIABLE FOR INCIDENTAL OR CONSEQUENTIAL DAMAGES. SOME STATES DO NOT ALLOW THE EXCLUSION OR LIMITATION OF INCIDENTAL OR CONSEQUENTIAL DAMAGES, SO THE ABOVE LIMITATION OR EXCLUSION MAY NOT APPLY TO YOU. THIS WARRANTY IS IN LIEU OF ALL OTHER EXPRESS OR IMPLIED WARRANTIES. ALL IMPLIED WARRANTIES, INCLUDING THE WARRANTY OF MERCHANTABILITY AND THE WARRANTY OF FITNESS FOR A PARTICULAR PURPOSE, ARE HEREBY MODIFIED TO EXIST ONLY AS CONTAINED IN THIS LIMITED WARRANTY, AND SHALL BE OF THE SAME DURATION AS THE WARRANTY PERIOD STATED ABOVE. SOME STATES DO NOT ALLOW LIMITATIONS ON THE DURATION OF AN IMPLIED WARRANTY, SO THE ABOVE LIMITATION MAY NOT APPLY TO YOU.

This warranty service is available by either (a) returning the product to the dealer from whom the unit was purchased, or (b) mailing the product, along with proof of purchase, postage prepaid to the authorized service center listed below. This warranty is made by: Intermatic Incorporated/After Sales Service/7777 Winn Rd., Spring Grove, Illinois 60081-9698/815-675-7000 <http://www.intermatic.com> Please be sure to wrap the product securely to avoid shipping damage.

INTERMATIC INCORPORATED
SPRING GROVE, ILLINOIS 60081-9698