

Installation Date \_\_\_\_\_

Battery

Replacement

Recommended \_\_\_\_\_

(8 years after installation)

 **INTERMATIC INCORPORATED**

<http://www.intermatic.com>

Intermatic Plaza, Spring Grove, Illinois 60081-9698

©Copyright 1998 Intermatic Inc.

158ET9624



Models ET70415CR, ET70415CR24,  
ET70215C8, ET70215CR24

Vol. 3

## ▼ INSTRUCTIONS Pg.

- INTRODUCTION 2
- LED Display 3
- RESET 3
- RUN/SET 3
- SET UP 4
- PROGRAM 4
- Keypad 5–10
- Load Controls 10–11
- Reviewing/Revising Data 12–16
- Programming Example 17–19
- Battery Backup 19

## ▼ CHARTS Pg.

- Switching Times 20–21
- HOLIDAY Reference # 22
- HOLIDAY Switching Times 23

## ▼ REFERENCE Pg.

- ASTRO and Time Zones 24–25
- Special Instructions 26–29
- Typ. Wiring Configurations 30–31
- Troubleshooting 32–37
- Error Messages 37–38

## INTRODUCTION

This easy to program microprocessor-based time switch provides flexible 24-hour, 7 day or full year load control. Its unique “self-prompting” feature simplifies programming by leading you through with flashing prompts. The 2 rows of LEDs on the left side flash and indicators in the digital display light while you are programming to identify information that needs to be entered.

**SET UP** information must be entered first, followed by the **PROGRAM** information. **PROGRAM** is used to set the switching times of the loads controlled by the time switch. Switching times can be programmed in any combination of:

**Fixed**—Switch ON times and/or Switch OFF times that are based on a user-selected time of day and can only be changed by reprogramming.

**Pulse**—The same as fixed times except the ON or OFF operation occurs only for a short duration (1 to 127 sec.) as required for bell ringing, signal control or the operation of latching relays.

**Interval**—The same as Pulse times except for a longer duration (from 1 min. minimum up to 6 days, 23 hrs., 59 min.).

Interval and Pulse also allow programming for a user selectable override.

**Astro**—Based on the changing times of sunset and sunrise.

Before proceeding with programming:

- Read the instructions on pgs. 3–16
- Review the programming example on pgs. 17–19
- Complete the charts on pgs. 20–23
- Install time switch, connect ground wire as shown on pgs. 26–29
- Complete wiring by referencing examples on pgs. 30–31

While programming be sure to assign the various switch times to the appropriate loads with the **Enable** switch. When you are finished, the **REV** (Review) key allows you to check the program before leaving the installation.

## LED DISPLAY

The red LED display prompts and indicates data as it is entered in **SET UP** and **PROGRAM**. The display indicates current time in the **RUN** mode. Note the dual captions above and below the display.

## RESET ●

Operation begins with **RESET**, followed by data entry with the keypad. Pressing **RESET** initializes the time switch by testing and clearing the working memory and turning off all circuit loads. (Pressing **RESET** during programming will cause all data just entered to be lost.) To clear all existing program and setup data, press and hold the **CLEAR** key, then press and release **RESET**. Continue to hold **CLEAR** until **RESET** appears in the display.

## RUN/SET



You must have this switch in the **SET** position to enter, review or clear data. When you have finished, slide the switch to **RUN** to automatically save the data into non-volatile memory. If entering a large number of set points, you may wish to periodically move the slide switch to **RUN** to save your data. Return to **SET** after **SAVE** disappears from the display and continue programming. If a power outage occurs and you are in **SET**, all data not saved will be lost. The data is permanently stored unless the memory is deliberately erased (by pressing **RESET** while holding down the **CLEAR** key). Data can only be modified by the user. In the event of power failure the non-volatile memory holds the data even if the battery backup should fail. When moving this switch to **RUN**, the message **SAVE** briefly appears in the display. When moved to **SET** the message **RECALL** appears briefly.

Data entry falls into the two categories shown on the front panel: **SET UP** and **PROGRAM**.

## ▼ SET UP

SET UP is performed once during installation to set the internal CLOCK, ASTRO (sunrise/sunset) times and HOLIDAY references. After entering and okaying the ASTRO Zone, the timer will display calculated “center of time zone” times when prompting for sunrise and sunset entries. You may OK these, enter actual sunrise/sunset times or enter offset times for early or late ASTRO operation. Sunrise time must be before noon; sunset time must be after noon. Sunset must not be within 5 hours of sunrise. Both sunrise and sunset must be entered, even if only one is used for switching. If neither is required, you may skip ahead by pressing **HLDY** or **PROG** keys. (See map pp. 24–25 for details.) Holidays are entered with 2-digit reference numbers; a chart for recording the date(s) is located on page 22. Leap years are preset through the year 2094.

## ▼ PROGRAM

PROGRAM is used for entering or changing the switching schedule for loads wired into the time switch. You can program circuits separately or concurrently. Each entry affects loads whose **Enable** switches are in the enable position at the time of data entry. The time switch is shipped in a 12-hr. AM/PM mode; you can change to 24-hr. by removing a jumper on the circuit board (see Special Instructions). It can store a minimum of 400 events, depending on the data type entered. The time switch prompts you through SET UP and PROGRAM with LEDs that advance after each entry. There are five important points to remember:

- 1) The RUN/SET switch must be in the SET position to enter, review or change data.
- 2) You must press “OK” after each entry, before starting the next.
- 3) You must press **AM** or **PM** after entering time (unless programming Sunrise and Sunset or in 24-hour mode).
- 4) When in PROGRAM you must select the loads you want to control with the **Enable** switches.
- 5) RUN/SET switch must be returned to RUN position to enable automatic control and to save changes to data.

## KEYPAD

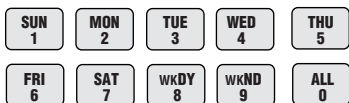

These keys are used for most data entry. Note dual functions, numeric or day specific. Using the day group keys **WKDY**, **WKND** and **ALL** (for all 7 days) greatly speeds the process.

The keypad keys are only functional when the **RUN/SET** switch is in the **SET** position. Pressing keys when in the **RUN** position will cause a message to scroll, explaining the function of that key. Press any key once to stop any of the scrolling error or help messages.



You must press **AM** or **PM** after entering time data (except Sunrise or Sunset) unless in 24-hr. mode. Programming fixed times for **ON** and **OFF** events does not require **PULSE**, **INTVL** or **ASTRO** keys. Multiple **ON**s or **OFF**s can be entered by pressing **OK** without programming the alternate **OFF** or **ON**. Multiple **OFF** times are frequently used to “sweep” off loads which have been manually switched on after normal occupancy hours.

**PULSE** and **INTVL** (Interval) are length-of-time based options. Maximum Pulse is 127 sec.; minimum is 1 sec. Maximum Interval is 6 days, 23 hrs., 59 min.; minimum is 1 min. To program Pulses or Intervals, press the **PULSE** or **INTVL** key after entering a **Switch On** or **Switch Off** time; then enter the required duration and press **OK**. Note after **ON** Pulses or Intervals have timed out the load will be **OFF**, and after **OFF** Pulses or Intervals have timed out the load will be **ON**, regardless of the load state prior to the start of the Pulse or Interval. The **INTVL** and **PULSE** keys include a temporary override function with a maximum length of 6 days, 23 hrs. and 59 min. for the interval or 127 seconds for the pulse.

To program an interval or pulse for override, select **SET**, enable the circuit, press **PROG**, press **INTVL** or **PULSE** (*without* selecting a day), key in the



interval or pulse duration, then press **OK**. Remember **INTVL** or **PULSE** override is initiated on demand via the keypad and is not based on a day and time, as is normal **INTVL** or **PULSE**. To initiate an override interval or pulse first set the **RUN/SET** switch to **RUN** and set the switch for the desired load to **Enable**, then press the **ON/OFF** key for the load you wish to override. The green load indicator flashes during the interval or pulse to show override selection. At the end of an override interval or override pulse, *initiated by the ON/OFF key*, the load and green LED will turn off, unless a programmed **ON** event has occurred during the override time period. This allows the override interval to be used as an “early **ON**” as well as a “late **OFF**” override after normal hours of operation without interfering with normal scheduled **ON/OFF** times. The load *will* respond to any subsequent program schedules. You may also initiate an override interval or pulse by pressing and holding the **INTVL** key, then pressing the **ON/OFF** key for the **Enabled** circuit you wish to override. This allows an override to be started without turning off a load that is already on. This is useful for **HID** lighting applications where even a brief turn off will cause loss of lighting for several minutes. Note that override can only be set for an interval or pulse, not both.

An override interval or pulse may be ended early *only* by pushing the **ON/OFF** key or by a power interruption. Thus, a programmed **OFF** event will not end an override interval or pulse. At the same time, any **ON** or **OFF** events which occurred during the override period will be in effect at the completion of the override time period. This allows applications such as a programmed **ON** time of 8:00 A.M. with a 2 hour interval override initiation at 7:30 A.M. At 9:30 A.M., after the two hour override, the lights will remain **ON** since during the override period they were programmed to switch **ON** (at 8:00 A.M.).

The override pulses are precise to-the-second whereas override interval duration is the program duration  $\pm$  30 seconds, dependent on the instant in time when the override was initiated.

The remote **Override** feature allows a switch contact to initiate an override interval or pulse. The timer detects the closing or opening of switch contacts wired to the **Remote Override Connector** (on back of **Logic Module**). This allows the remote switch(es) to be

maintained (toggle) or normally open or normally closed momentary (pushbutton). As with the front panel initiated override interval or pulse., the relevant circuit must have either an interval or pulse duration programmed and its slide switch must be in the **Enable** position, before an override interval or pulse can be initiated. Any additional remote switch activity during the interval or pulse will restart it. At the end of a *remotely* initiated override interval or pulse, the circuit will return to its normally programmed condition.

If no interval or pulse duration has been programmed for a given circuit, the remote override can be used as a remote ON/OFF switch. The relevant circuit must be enabled. Each push of the remote pushbutton or flipping of the remote toggle switch will cause that circuit to change to the opposite state. As with overrides initiated by the front panel ON/OFF key, the circuit will respond to any subsequent programmed schedules. See Special Instructions for wiring.

**ASTRO** is pressed (instead of a time entry) after selecting a day or day group if you want switching to occur at Sunrise and/or Sunset. If **ASTRO** is pressed during the “Switch On” prompt, the timer prompts for sunset. If **ASTRO** is pressed during the “Switch Off” prompt, the timer prompts for sunrise. For applications requiring an ON event at sunrise and/or an OFF event at sunset, press **AM** or **PM** respectively to toggle the sunrise/sunset prompts.

Interval programming may be used to extend the “Switch On” and “Switch Off” times of **ASTRO** schedules. This is useful when some circuits require differing offsets from the **ASTRO** ON/OFF times that were entered during SET UP. To use this feature, enter the earliest required **ASTRO** ON/OFF times during SET UP, then use intervals of various durations to delay the ON/OFF times as required. Specifically, use an ON interval to delay an **ASTRO** turn OFF time and use an OFF interval to delay an **ASTRO** turn ON time. Refer to the “Programming Examples” booklet for detailed instructions. To program **ASTRO** switching with a Pulse or Interval, press **ASTRO**, then **PULSE** or **INTVL**, followed by entering a pulse or interval duration. . . all before **OK** is pressed.



(Clock adjustment for Daylight Savings Time (DST) is automatic; see Special Instructions for override if DST adjustment is not required, such as in Arizona, Hawaii and parts of Indiana. The clock time will be adjusted by 1 hour on the first Sunday of April and the last Sunday of October at 2:00 A.M. Due to unexpected results, it is recommended you do not attempt programming from 12:00 midnight to 2:00 A.M. on these two days.)

**PROG** **REV** **SET UP** **HLDY** **PROG** (Program) and **SET UP** return you to the beginning of these categories. Press **PROG** to select a new day/day group when programming of a selected day/day group is complete, or to skip Astro and/or Holiday prompts during **SET UP**.

**REV** (Review) allows you to check **SET UP** or **PROGRAM** data. The holidays will review in chronological order regardless of the order in which they were entered. **CLEAR** is used during Review to delete displayed data if changes are required.

The Holiday (**HLDY**) feature allows the timer to follow special schedules on selected days or periods of days, based on the date instead of the usual 7 days of the week. Although Holiday schedules are normally used to modify or suspend regular weekly switching activity on actual holidays, the Holiday feature also allows a variety of special scheduling options that are not satisfied by the 7-day repeating schedule. See Programming Examples supplement for details. Each holiday may be one day long or as many days as necessary. Although each has a reference number (1–99) that you assign, Holidays occur and review in chronological order, so the order of the reference numbers does not matter.

**HLDY** (Holiday) allows you to set up or review Holiday data. If a holiday is a single day, press **OK** when prompted for the Stop date, or enter the same date. Holiday scheduling applies to all 4 circuits. If you need to switch loads on a holiday, press **PROGRAM**, press **HLDY**, enter the reference number 1–99 for that holiday, then press **OK**. Program the holiday load schedule just as you would any day or day group. If you do not program switching times for holidays, the loads will be inactive during the holiday period; all loads will remain in the state they were at 11:59 P.M. on the day preceding the start of the holiday. You may program Off events at 12:00 A.M. on holidays to guarantee loads are off during holidays.

Note the Stop date is the last day the loads will be inactive or under special program control. The following day the loads will resume normal scheduling beginning at 12:00 A.M. Press **PROG** to exit the holiday mode after entering the last holiday.

Holiday schedules and dates will remain in timer memory until deliberately cleared. For those Holidays whose dates vary from year to year, you must manually revise the start and stop dates (in SET UP review) annually. Holidays may not be programmed to end before their start date and must end by Dec. 31. During days when the timer is following a holiday schedule the "Ref#" LED will blink to indicate that Holiday scheduling is in effect.

**OK** **CLEAR** **COPY** **HELP** The **OK** key must be pressed after each complete entry; pressing it advances you to the next data prompt. The **OK** key is similar to an Enter key. After okaying a switching time, the timer automatically prompts for the alternate switching activity; i.e. Off after On, On after Off (except after a pulse or interval entry). Pressing the **OK** key without making another switching time entry alternates the On/Off prompt, allowing a succession of Off or On events. **OK** is the *final step* after programming all steps and enabling circuits for each switching time/type.

**CLEAR** clears the last digit entered; additional digits are cleared from the display each time **CLEAR** is pressed. **CLEAR** is also used to clear an error code or message and return the display to the same data that appeared before attempting to OK the data.

While in Review pressing **CLEAR** deletes the displayed data from the program for the load(s) selected with **Enable**. Press **REV** to continue Review.

**COPY** allows you to use the same schedule for groups of days other than those available on the keypad (WKDYs, WKNDs or ALL). Simply press **COPY** after entering a schedule for a specific day, and at the DAY prompt key in the day you wish to copy to, then press **OK**. You may also copy a day that was previously programmed by pressing that day's key, pressing the **OK** key, then the **COPY** key.

The display will show the selected day followed by COPY. Now key in the day you wish to copy to and press OK to confirm.

Select and OK additional copy to days as required.

Four rules need to be followed when using COPY:

- 1) You cannot copy to a day that has already been programmed.
- 2) You cannot copy from a day which has already been copied to.
- 3) You cannot copy to or from a day group.
- 4) The COPY feature copies the programmed schedules of all the circuits of the copy from day to the corresponding circuits of the copy to day regardless of the positions of the circuit **Enable** switches. Individual circuit schedules may not be copied independently (2 circuit models only).

HELP provides help messages specific to each step in SET UP and PROGRAM. If you make an error, it will be indicated in the LED display with an error code. (See Error Messages at the back of this booklet, or press **HELP** to scroll the message across the display.)

Pressing any key or allowing the message to finish returns the display to the condition before the error was made.

## LOAD CONTROLS

**Enable**      There are two controls and an LED indicator for each load. **Enable/Disable** activates automatic switching of the load by the time switch, enables the override function in **RUN** mode and selects circuits being programmed in **SET** mode.



**Disable**

The **ON/OFF** key manually switches the load independently of the time switch and cancels any previously initiated activity, including **PULSEs**, **INTVLs** (Intervals) or override intervals and override pulses. If an override interval or pulse has been programmed, pressing the **ON/OFF** key of a circuit that is Enabled will initiate that override. In order to manually switch the load ON or OFF in this situation, you must slide the **Enable/Disable** switch to **Disable**, press the **ON/OFF** key, then return the slide switch to **Enable** in order to allow the time switch to follow subsequent set points. The **ON/OFF** key does not interfere with events that occur after its use. The **ON/OFF** keys and LEDs will operate the loads and indicate status regardless of the position of the **RUN/SET** switch.

The green LED is ON when the normally open contacts are closed. Typical wiring methods will mean that the green LED is ON when the load is ON. Verify this by trial and error if in doubt. If the circuit is on due to an override interval or pulse, the green LED will be flashing.

When timer power is restored after a power interruption, all loads will initially be OFF. The timer then restores any enabled loads to their programmed status as of midnight (12:00 AM) of the present day. For this reason, for ON periods that include midnight, if load operation is desired immediately after power restoration, use a redundant ON set point at each affected midnight (12:00 AM) to guarantee predictable catch-up. Using this same technique is recommended when Astro ON periods include midnight.

If more than one load is scheduled to turn ON, the soft start feature will turn them ON successively at 15 sec. intervals. Therefore, it is generally advisable to put lighting loads on low-numbered circuits to hasten their turn-on after power is restored. All same-scheduled loads turn OFF simultaneously at the scheduled time. If a soft start is not desired, program those loads using interval or pulse.

Loads that are operated by pulses (such as latching contactors) may not be restored to the expected condition if any ON/OFF pulses occurred during the power interruption. Consider using fixed ON/OFF schedules in conjunction with either self-clearing contactors or contactors adapted for “two wire control”.

## **INSTRUCTIONS FOR REVIEWING/REVISING DATA**

### **REVIEW PROCEDURE**

- Place the RUN/SET switch in the SET position to review.
- You must review Clock info (day of week, time, date), Astro and Holiday dates in SET UP mode.
- You must review all load activity (Fixed times, Astro times, Pulse operations, Interval operations and special “Holiday” load activities) in PROGRAM mode.
- In PROGRAM, select only one load at a time using the Enable switch. If more than one circuit is enabled, you will only see switch activities common to all Enabled circuits.

### **REVIEW CLOCK, CALENDAR, ASTRO DATA AND HOLIDAY DATES**

To initiate review, press SET UP (day of week/time are displayed), then press REV (Review). Continue to press REV for each program you wish to review. SET UP stops after month, date and year are displayed if no Astro information has been entered, allowing you to enter Astro data (Zone, Sunrise and Sunset). If ASTRO information has been entered, pressing REV after reviewing the Sunset time will cause the message “End of Review” to be displayed. Review will then automatically advance to HOLIDAY, allowing you to select a specific holiday reference # (01–99) for review. If you want to review all holiday dates, press REV without selecting a reference number, and the first holiday reference # will appear. (This will not necessarily be reference #1 since holidays review in chronological order beginning January 1st). Continue to press REV to walk through the Ref # and the Start and Stop dates for each holiday until “End of Review” is displayed. For single day holidays, Start and Stop dates will be the same. Note that Astro sunrise and sunset times are re-calculated daily by the timer and will differ from times entered or reviewed on a previous date.

### **REVISE SET UP DATA**

To revise or delete displayed information during Set Up Review, simply press CLEAR. When reviewing Astro Sunrise and Sunset times, you may need to press CLEAR more than one time since

each operation deletes only one digit. You can then immediately make the revision. Be sure to press **OK** to enter the new data. Note that after any revisions to the sunrise Astro time, the sunset Astro time must be re-entered and okayed. Press **REV** to continue the review.

## **REVIEW PROGRAM**

- Be sure to select one load at a time. Failing to do so will allow you to only review switching activities which are common to all circuits. In other words, if circuits #1 and circuits #2 are both enabled and are both programmed to come On at 8:00 A.M., but Off at different times, the 8:00 A.M. On time will be the only set point shown in Review. You must be in the PROGRAM mode in order to review the programmed load activities.
- In the PROGRAM mode, you can review switching activities regardless of whether you programmed them as Fixed Times, Astro Times, Pulse Switching or Interval Switching. Special Holiday load activities or interval overrides are also reviewed in Program.

## **REVIEW WEEK LONG SWITCHING ACTIVITIES**

The normal load switching schedule is a composite of all applicable individual day schedules, day group schedules and copied days. The week long review feature allows this composite schedule to be easily reviewed; by simply pressing the **REV** key repeatedly, without first selecting a day, the timer will step thru all scheduled switching times chronologically, beginning at 12:00 A.M. Sunday, or by pressing the **REV** key once, then pressing the **OK** key, the timer will automatically step thru each scheduled switching time, displaying each time for about 2 seconds. Press the **OK** key to pause auto review. Press the **OK** key again to resume auto review; or press the **REV** key to continue review manually. The scheduled switching times may only be reviewed, not cleared during week long review. Follow the steps below for individual day/day group review if any scheduled events need to be cleared.

## REVIEW INDIVIDUAL DAY, DAY GROUP, OR COPIED ACTIVITIES

- Press **PROG**, then press the day key (SUN/1 through SAT/7) or the day group key (wkDY/8, wkND/9 or ALL/0) to select the day or day group to review.

NOTE: If you have entered data as a day group and attempt to review any of the days individually, the message “End of Review” will be displayed. This is because you must review data just as it was entered, in this example, as a day group.

- Press **REV**, at which point the colon will disappear. Press **REV** again to review the first programmed switch time. The associated Switch On or Switch Off LED will be lit.
- Press **REV** again to review the next activity. If a switching time includes a pulse or interval when you press **REV**, the length of the pulse or interval will be displayed and the LED for PULSE or INTVL will be lit. Continue to press **REV** until “End of Review” is displayed. The display now prompts for a new day or day group selection. Repeat the steps above for each circuit individually.
- To automatically review a day or day group, press **PROG**, select a day (SUN/1 thru SAT/7) or day group (wkDY/8, wkND/9 or ALL/0), press **REV**, then press **OK**. If desired, press **OK** again to pause auto review; press **OK** again to resume review, or press **REV** to continue reviewing manually.
- If a day was copied from, you may review all days it was copied to by selecting the copy from day, pressing **OK**, pressing **COPY**, then pressing **REV**. For example, display might show 1 COPY 2 meaning that the day 1 schedule has been copied to day 2. Push **REV** more times to review additional copy to days. If a day is a copy, you may determine the day it was copied from by selecting the day then pressing **REV** twice. A message will scroll indicating the day it was copied from.
- Individual day review is not recommended for verifying predicted operation of the timer because, since the actual schedule is the composite of days, day groups, and copied days, all of these would need to be reviewed, then manually combined, to know the actual schedule for a given day. For example, if the weekday (8) day group has scheduled activity, but no individual weekdays (Monday thru Friday) have scheduled activity,

reviewing Monday only would immediately give the “End of Review” message, indicating no activity, yet there will be activity on Monday due to the weekday (8) day group schedule.

Therefore, always use the week long review feature for final verification of the complete schedule.

NOTE: The effect of Holiday schedules cannot be seen during week long review, so in addition to week long review, all Holidays should also be reviewed to accurately predict the timer’s operation.

## REVIEW SPECIAL HOLIDAY SWITCHING ACTIVITIES

To review special holiday switching activities, press **PROG** then **HLDY**. Next enter the holiday reference number (01 to 99) for the holiday activities you wish to review. Press **OK**, then press **REV**, at which point the colon will disappear from the display. Press **REV** again to display the first switching activity. Continue to press **REV** while observing the LED prompts and program times and/or Pulse and Interval times until “End of Review” is displayed. Automatic review can also be used by pressing **PROG**, **HLDY**, then entering the Holiday reference #, **OK**, **REV**, then **OK**. If desired, press **OK** key to pause and resume auto review.

## REVIEW OVERRIDE INTERVAL/OVERRIDE PULSE OPERATION

- Press **PROG** and do not select a day or day group.
- Press **INTVL**. The interval duration in days, hours and minutes as programmed will be displayed.
- Press **PULSE**. The pulse duration in seconds as programmed will be displayed.
- When reviewing data, the appropriate **Enable** switch must be used, one switch at a time.

## REVISE PROGRAM DATA

When revising program data, make note of the following:

- **RUN/SET** switch must be in **SET** position
- Data is revised by causing it to be displayed during Review, deleting it with the **CLEAR** key, and then replacing it with new data, if desired.
- Program data may not be revised during week long



review. You must revise the data by reviewing the appropriate individual day, day group, or “copied from” day.

- During automatic review, the **OK** key must be used to pause the display before the displayed data can be deleted.
- After any program data is cleared, review is terminated. The timer is now in the program mode for the selected day, anticipating a new entry. You may make the new entry, restart review, or return to **RUN** position.
- It is recommended that you repeat the “week long review” after any revisions are complete to verify that all revisions were implemented as desired.

To revise or delete displayed information during Program Review, simply press **CLEAR**. You can then immediately make the revision desired. Be sure to press **OK** to enter the new data. Press **REV** to restart the review. Note that you can delete a Pulse or Interval option from any Switch On or Switch Off time by pressing **CLEAR** when the time is displayed during Review. You must re-enter, then **OK** the Switch On or Switch Off time, even if it has not changed. Likewise, you may add a Pulse or Interval to a Switch On or Switch Off time by pressing **CLEAR** when the time is displayed. You must re-enter the time, press **PULSE** or **INTVL**, enter the length of Pulse or Interval, then press **OK**.

## **REVISE/DELETE HOLIDAY SCHEDULES AND DATES**

- To revise holiday Start/Stop dates: Press **SET UP**, then **HLDY**, then the Holiday # (if known), then **REV**. The selected Holiday # will show. Press **REV** again; the **START** date will show. Pressing **CLEAR** will delete the **START** and **STOP** dates. Enter the new **START** date, then **OK**. Enter the new **STOP** date, then **OK**.
- To revise holiday schedules: Press **PROG**, then **HLDY**, then the Holiday #. Press **REV** until the time that requires revision is displayed. Press **CLEAR** to delete the displayed time. Enter and **OK** a new time if desired.

- To delete a holiday# (and thus its Start/Stop dates) that has never had any scheduled On/Off times: Press **SET UP**, then **HLDY**, then the Holiday #, then **REV**, then **CLEAR**. If the display shows “\_”, the Holiday has been deleted. If “ERR 22” shows, this Holiday has, or once had, a schedule. If so, press any key to clear the error message then follow the steps below.
- To delete a holiday# (and thus its Start/Stop dates) when the holiday has or once had scheduled On/Off times: Enable any circuit, press **PROG**, then **HLDY**, then the Holiday #, then **REV**. The selected Holiday # will show. Press **CLEAR**; the timer will scroll a message asking if you are sure you want to delete the Holiday schedule. After the message stops and the Holiday # is re-displayed, press **CLEAR** to delete it. Now press **SET UP**, then **HLDY**, then the Holiday #, then **REV**, then **CLEAR**. The holiday is now completely deleted.

### **PROGRAMMING EXAMPLE** (2 circuits only)

Be sure **RUN/SET** switch is in **SET** position. At the initial installation and/or to clear out all previously programmed data, press and hold the **CLEAR** button, then press and release **RESET** and continue to hold the **CLEAR** button until **RESET** appears in the display. Note leading zeros are not required for the left-most prompted digit.

**Press** **SET UP** (unless prompt is flashing at **Day of Wk/Time**)

**Assume** • Current day and time is Tuesday, 2:30 P.M.

• Current date is January 21, 1997

• Location is Des Moines, Iowa (Zone 5 from Astro Zone Map and center of Central time zone)

• The building owner wants the lights Off 30 min. after sunrise and On 30 min. prior to sunset.

• Two Holiday or special schedules – July 4th and a 2-week office closing 12/22/97 thru 1/5/98

**Press** **TUE/3, OK** (selects day); **2, 3, 0, PM, OK** (selects time); **1, 2, 1, 9, 7, OK** (selects date); **5, OK** (selects zone).

The time switch now displays the calculated center of time zone sunrise time of -7:33 A.M. Since the building

owner wants to offset actual sunrise time by having lights switch off 30 min. late, press **CLEAR, CLEAR, CLEAR** (deletes automatic center of zone calculation; display now shows --:--) and **8, 0, 3, OK** (selects new offset sunrise time). The time switch now displays the calculated center of time zone sunset time of -5:13 P.M. Since the building owner wants to offset actual sunset time, press **CLEAR, CLEAR, CLEAR** (deletes automatic center of zone calculation; display now shows --:--); **4, 4, 3, OK** (selects new offset sunset time); **1, OK** (selects first Holiday schedule Ref. # for 1997); **7, 0, 4, OK, OK** (pressing **OK** twice selects same start and stop date); **2, OK** (selects second Holiday schedule Ref. #); **1, 2, 2, 2, OK** (start date); **1, 2, 3, 1 OK** (stop date); **3, OK** (selects first Holiday schedule Ref. # for 1998); **1, 0, 1, OK** (start date) and **1, 0, 5, OK** (stop date). SET UP is now complete.

**Press** **PROG** (to enter PROGRAM mode and exit SET UP)

- Assume**
- Programming for two loads: #1 indoor lighting, #2 buzzer
  - Load 1 switches On 7:50 A.M. to 4:40 P.M. Monday thru Friday and 7:50 A.M. to 12:00 P.M. noon Sat. only.
  - Load 2 operates the signal twice daily for 15 sec. at 8:00 A.M. and 4:30 P.M. Monday thru Friday only.

**Set** Load slide switches to **Enable Load 1** and **Disable 2**  
**Press** **WKdy/8, OK** (selects weekdays only); **7, 5, 0, AM, OK** (load On time); **4, 4, 0, PM, OK** (load Off time)

**Set** Load slide switches to **Disable Load 1** and **Enable 2**  
**Press** **8, 0, 0, AM, PULSE, 1, 5, OK** (selects 15 sec. load On at 8:00 A.M.); **4, 3, 0, PM, PULSE, 1, 5, OK** (selects 15 sec. load On at 4:30 P.M.)

**Press** **PROG** to select a new day or day group to program.  
**Set** Load slide switches to **Enable Load 1** and **Disable 2**  
**Press** **SAT/7, OK** (selects Saturday only); **7, 5, 0, AM, OK** (load On time); **1, 2, 0, 0, PM, OK** (load Off time)

Scheduled PROGRAM is now complete.

**Assume** A 30 min. INTERVAL override duration is desired for Load 1.

**Set** Load slide switches to **Enable Load 1** and **Disable 2**

**Press** **PROG** (completes programming for Saturday data)  
**INTVL, 3, 0, OK** (sets user selectable interval duration to 30 minutes)

(Note a day or day group is not selected since Interval override is selected on demand by the building occupants.)

**Interval override duration** selection is now complete.

The interval override will not begin until called for by the user via the front panel pushbuttons.

To complete programming, download all data into non-volatile memory by sliding the **SET/RUN** switch to **RUN**. Note **SAVE** is displayed momentarily and the current day of week and time appear in the display.

**NOTE:** If you need more programming assistance, request form #158ET9311, Programming Examples, which contains step-by-step instructions for several complex programs.

## **BATTERY BACKUP**

All programmed data is protected by non-volatile memory and can only be changed or deleted by reprogramming, regardless of power outage durations. A factory installed 8-year lithium battery backup maintains accurate time and calendar information.

See Special Instructions for replacement.

## SWITCHING TIMES

Day/Day Group	CIRCUITS				SWITCH ON		SWITCH OFF		PULSE	INTVL Override		ASTRO
	1	2	3	4								
					:	AM	:	AM	Sec	/	:	N O  T I M E  E N T R Y  R E Q U I R E D
					:	PM	:	PM	Sec	/	:	
					:	AM	:	AM	Sec	/	:	
					:	PM	:	PM	Sec	/	:	
					:	AM	:	AM	Sec	/	:	
					:	PM	:	PM	Sec	/	:	
					:	AM	:	AM	Sec	/	:	
					:	PM	:	PM	Sec	/	:	
					:	AM	:	AM	Sec	/	:	
					:	PM	:	PM	Sec	/	:	
					:	AM	:	AM	Sec	/	:	
					:	PM	:	PM	Sec	/	:	
					:	AM	:	AM	Sec	/	:	
					:	PM	:	PM	Sec	/	:	
					:	AM	:	AM	Sec	/	:	
					:	PM	:	PM	Sec	/	:	
					:	AM	:	AM	Sec	/	:	
					:	PM	:	PM	Sec	/	:	
					:	AM	:	AM	Sec	/	:	
					:	PM	:	PM	Sec	/	:	

# SWITCHING TIMES

Day/Day Group	CIRCUITS				SWITCH ON	SWITCH OFF	PULSE	INTVL Override	ASTRO
	1	2	3	4					
					: AM PM	: AM PM	Sec	/ :	N O  T I M E  E N T R Y  R E Q U I R E D
					: AM PM	: AM PM	Sec	/ :	
					: AM PM	: AM PM	Sec	/ :	
					: AM PM	: AM PM	Sec	/ :	
					: AM PM	: AM PM	Sec	/ :	
					: AM PM	: AM PM	Sec	/ :	
					: AM PM	: AM PM	Sec	/ :	
					: AM PM	: AM PM	Sec	/ :	
					: AM PM	: AM PM	Sec	/ :	
					: AM PM	: AM PM	Sec	/ :	
					: AM PM	: AM PM	Sec	/ :	
					: AM PM	: AM PM	Sec	/ :	
					: AM PM	: AM PM	Sec	/ :	
					: AM PM	: AM PM	Sec	/ :	
					: AM PM	: AM PM	Sec	/ :	
					: AM PM	: AM PM	Sec	/ :	
					: AM PM	: AM PM	Sec	/ :	
					: AM PM	: AM PM	Sec	/ :	
					: AM PM	: AM PM	Sec	/ :	
					: AM PM	: AM PM	Sec	/ :	



**HOLIDAY REFERENCE #** (Up to 99 holidays or holiday durations can be programmed)

HOLIDAY	START Month/Date	END Month/Date
01	/	/
02	/	/
03	/	/
04	/	/
05	/	/
06	/	/
07	/	/
08	/	/
09	/	/
10	/	/
11	/	/
12	/	/
13	/	/
14	/	/
15	/	/
16	/	/
17	/	/
18	/	/
19	/	/
20	/	/
21	/	/
22	/	/
23	/	/
24	/	/
25	/	/
26	/	/
27	/	/
28	/	/
29	/	/
30	/	/

## HOLIDAY SWITCHING TIMES

HOLIDAY Ref #	CIRCUITS				SWITCH ON		SWITCH OFF		PULSE	INTVL Override	ASTRO
	1	2	3	4							
					:	AM	:	AM	Sec	/ :	N O  T I M E  E N T R Y  R E Q U I R E D
					:	PM	:	PM	Sec	/ :	
					:	AM	:	AM	Sec	/ :	
					:	PM	:	PM	Sec	/ :	
					:	AM	:	AM	Sec	/ :	
					:	PM	:	PM	Sec	/ :	
					:	AM	:	AM	Sec	/ :	
					:	PM	:	PM	Sec	/ :	
					:	AM	:	AM	Sec	/ :	
					:	PM	:	PM	Sec	/ :	
					:	AM	:	AM	Sec	/ :	
					:	PM	:	PM	Sec	/ :	
					:	AM	:	AM	Sec	/ :	
					:	PM	:	PM	Sec	/ :	
					:	AM	:	AM	Sec	/ :	
					:	PM	:	PM	Sec	/ :	
					:	AM	:	AM	Sec	/ :	
					:	PM	:	PM	Sec	/ :	
					:	AM	:	AM	Sec	/ :	
					:	PM	:	PM	Sec	/ :	

**NOTE:** Holidays not programmed for switching times will automatically skip all load activities normally associated with the day(s) that the holiday(s) occur.



# TIME ZONES

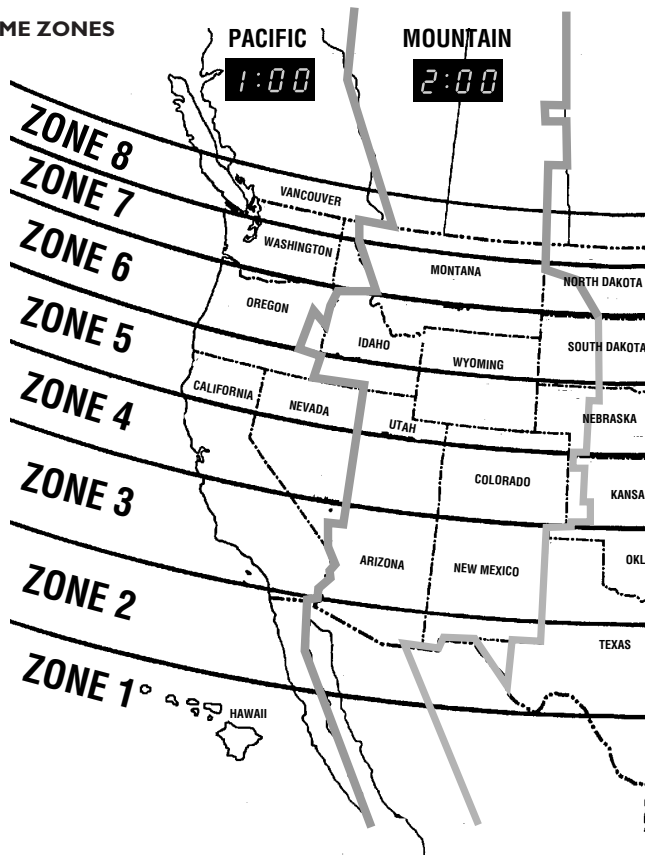

After the astro zone is entered the approximate sunrise and sunset times for the center of the time zone will be displayed. Depending on your location relative to the center, you may want to change (offset) this time. Following are approximate offsets (plus or minus) for selected cities in 5 minute increments.

	SUNRISE	SUNSET
Albuquerque	-5	-5
Atlanta	+25	+25
Baltimore	-5	-5
Bangor, ME	-35	-35
Boston	-30	-30
Chicago	-20	-20
Cleveland	+15	+15
Dallas	+15	+15
Denver	-10	-10
Des Moines	0	0

	SUNRISE	SUNSET
Detroit	+20	+20
El Paso	-5	-5
Houston	+10	+10
Honolulu	+20	+20
Las Vegas	-30	-30
Los Angeles	-20	-20
Miami	+10	+10
New York	-15	-15
Oklahoma City	+20	+20
Philadelphia	-10	-10

	SUNRISE	SUNSET
Phoenix	+15	+15
Pittsburgh	+10	+10
Portland, OR	0	0
Richmond, VA	0	0
San Diego	-25	-25
San Francisco	0	0
Seattle	-5	-5
Tampa	+20	+20

You may also check the local newspaper for actual local times.

## SPECIAL INSTRUCTIONS

**Enclosure Mounting** The top mounting hole on the enclosure bracket is slotted; it is not necessary to remove the power module unless you want to change the input voltage. If the change is required to meet your available voltage, remove the power module before mounting the enclosure. Mount the enclosure with #8 or 10 pan head or #6 or 8 hex head screws. The cover can be removed by lifting upward off hinges for convenience in installation.

**WARNING:** Disconnect all power at the service panel before removing the logic module.

**Removing Logic Module** (required for wiring). Pull the retaining tab to the left and lift logic module away on the left side.

**STOP:** Disconnect cable from rear of logic module by pulling straight back on the cable.

### Opening the Logic Module

To remove the metal logic module cover, remove the screws on the back and lift off, exposing the circuit board. Reverse steps to replace cover. The following three procedures require cover removal.

### Converting to 24 Hour Display Mode

The time switch is shipped with 12 hr. AM/PM timekeeping; 24 hr. is available by removing the jumper from the pin connector on the circuit board. The jumper(s) may be stored for later use by reinstalling on the outer pins only.

**Daylight Saving Time Override** Override the automatic DST adjustment (in Arizona, Hawaii and parts of Indiana) by removing the jumper on the circuit board.

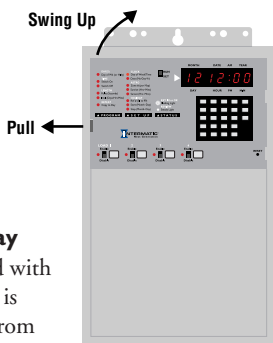

## SPECIAL INSTRUCTIONS

**Battery Replacement** The 8 yr. lithium battery is located on the back of the circuit board under the metal battery terminal clips. Replace with Panasonic or Rayovac BR2325 (or equivalent).

**Re-installing Logic Module** Carefully plug the 10 wire cable straight into the connector on the rear of the logic module. The sawtooth shape on both connectors must line up to allow the cable connector to be seated. Engage the cut-aways on the right side of the logic module with the guides in the plastic terminal block and snap the left hand side in place. It may be necessary to use a small screwdriver to push the left hand retaining tab slightly to the left to allow the module to snap in place.

**Removing Power Module (required to change input voltage or to access rear power input terminals—24 Volt Model)** Remove the logic module. Remove the (3) screws that secure the power module to the enclosure. Use the logic board retaining tab to lift the power module out of the enclosure.

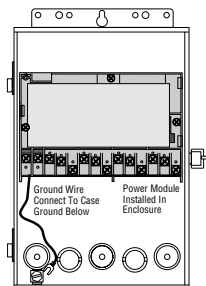

POWER MODULE  
(front view)

## SPECIAL INSTRUCTIONS

### Changing Power Input Voltage— Multi-Volt Model ET70415CR

This model can be powered by any industry standard 50–60Hz AC voltage, 120 to 277V. To change from the 120VAC factory setting, locate the voltage selector jumper and insert over the pair marked with the desired voltage (208, 240, or 277 VAC).

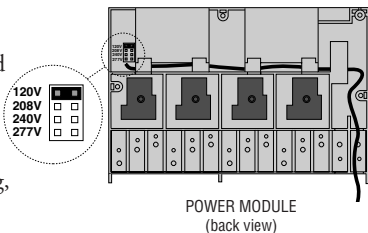

### 24 Volt Wiring—When Using Bell or Thermostat Wire Model ET70415CR Only (Load Voltage Above 24 Volts)

This timer must be powered by 24 VAC, 60 Hz only. There is no supply voltage adjustment jumper. If load voltage(s) are 24V or less, and/or if the timer power wiring insulation is rated for at least 300V, connect timer power to terminal 1 and 2. If load voltages are greater than 24V and the timer power wiring insulation is not rated for at least 300V, such as bell or thermostat wire, feed the timer power wiring through the supplied insulating tube and connect to the two-place terminal block on the back of the power module. Once installed, the tubing must extend beyond the enclosure wall and under the power module so that the timer power wiring remains isolated from the high voltage load wiring.

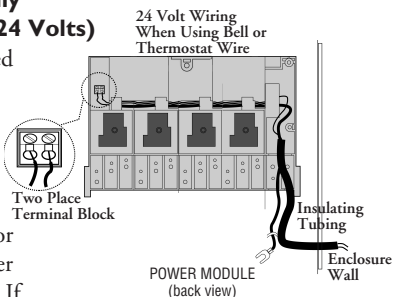

## SPECIAL INSTRUCTIONS

**Load Control Wiring** With the logic module removed you have access to the load control relay terminals. Refer to diagrams on following pages for terminal designations.

NOTE: Contacts are isolated to enable switching loads of a voltage different than the timer power voltage. You may need to connect power to the common (COM) terminals. Add jumpers as required. Do not mix solid and stranded wires under the same terminal.

Remote Override Loop override wires in upper compartment as shown to facilitate removal and installation of logic module.

When installing logic module, you must make sure override wires are placed in upper compartment, above the power module, or the logic module will not install properly. Route wiring and insulating tube through passages in bottom walls of terminal block as shown.

The supplied insulating tube must be used if customer-supplied field wiring does not have 300 volt or greater rated insulation (such as bell or thermostat wire). The tubing must extend into the connector insulator and must extend beyond the enclosure wall (typically into the conduit).

Note: Illustration shows only circuits 1 and 2 wired for remote override.

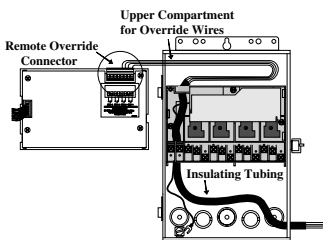

REMOTE OVERRIDE WIRING

## TYPICAL WIRING CONFIGURATION

(Multi-volt Model) (ET70415CR)

**WARNING:** If timer power supply voltage is 208/240/277V, you must move the input voltage selector jumper on the power board. See Special Instructions.

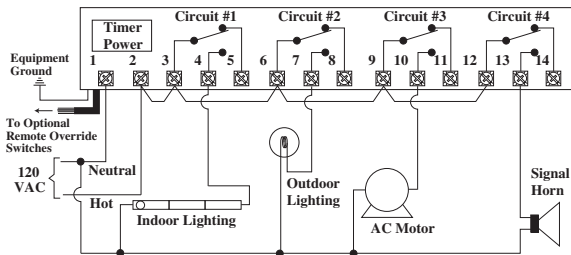

Example #1 All loads and timer powered by same source

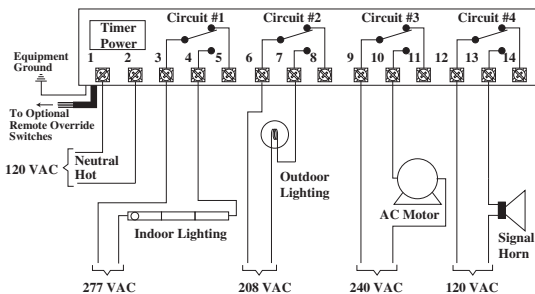

Example #2 Loads and timer each powered by different sources and voltages

**NOTE:** To enable switching loads of a voltage different than the timer power voltage, the outputs from this timer are isolated relay contacts. You need to connect a source of power to the common (COM) terminals as shown above. Do not mix solid and stranded wires under the same terminal.

# TYPICAL WIRING CONFIGURATION

24 Volt Model (ET70415CR24)

**WARNING:** Timer power supply voltage must be 24 VAC 60 Hz only. Refer to Special Instructions if any load voltages are greater than 24 volts.

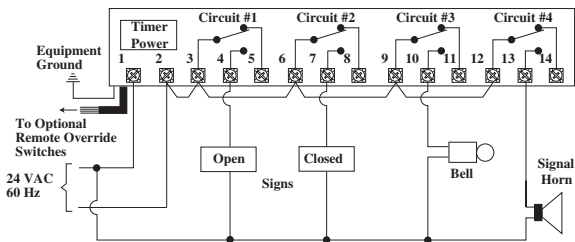

Example #1: All loads and timer powered by same source

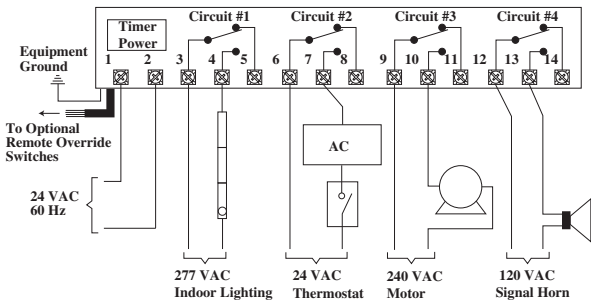

Example #2: Loads and timer each powered by different sources and voltages

**NOTE:** To enable switching loads of a voltage different than the timer power voltage, the outputs from this timer are isolated relay contacts. You need to connect a source of power to the common (COM) terminals as shown above. Do not mix solid and stranded wires under the same terminal.

## TROUBLE SHOOTING

Problem	Solution(s)
Display Does Not Light	<ul style="list-style-type: none"><li>• Make sure flat cable is properly plugged into the rear of the logic module. Refer to “Re-installing logic module” in Special Instructions. If connector will not install easily, check for bent pins.</li><li>• On multi-volt model make sure the voltage selector jumper is correctly installed and that matching voltage is present at timer power terminals. On 24V model make sure 24VAC is present at timer power terminals 1 and 2 or at the two place terminal block on the back of the power module.</li></ul>
Loads Not Switching	<ul style="list-style-type: none"><li>• Check wiring. Note the load contacts are isolated to allow you to switch loads with a voltage different than the timer power. You may have forgotten to add the appropriate connections required to power the load contacts. See wiring examples.</li><li>• Check to ensure all breakers or disconnects have been reset.</li><li>• Make sure load switches are in <b>Enable</b> position for automatic switching.</li><li>• After a power interruption all loads will be Off and will “catch up” to the present programmed state as of midnight of the present day. Schedules that turn On one day, then Off one or more days later, need a redundant switch On time at 12:00 A.M. Loads that are operated by pulses (such as latching contactors) may not be restored to the expected condition if any On/Off pulses occurred during the power interruption. Consider using fixed On/Off schedules in conjunction with either self-clearing contactors or contactors adapted for “two wire control”. See “Load Controls” for details.</li><li>• Make sure the <b>SET/RUN</b> switch is set to <b>RUN</b>.</li></ul>

- **NOTE:** Override intervals or pulses are not ended by scheduled OFF events; they can only be ended by timing out, power interruptions, or by pressing the ON/OFF key. At the termination of an override interval or pulse, the load may be on or off. If the override interval or pulse was initiated via the front panel ON/OFF key, the load will normally be off at the end of the override interval or pulse; the load will remain on only if an ON set point has occurred during the override interval or pulse. If the override interval or pulse was initiated via the remote override connector, the circuit will revert to its normally programmed condition at the end of the override interval or pulse.
- Review **SET UP** or observe the flashing “Holiday Ref” light to see if timer could be following a holiday program with no scheduled activity.

### Load Switches at Incorrect Time

- Using the REV function, check program times against the times you entered in the chart.
- Review **SET UP** or observe the flashing “Holiday REF #” light to see if the timer is following a holiday schedule. Holiday dates and schedules from the prior year do not automatically clear or adjust. They must be manually revised or removed annually.
- When using pulse or interval “ON” programming, the load will switch ON at the scheduled time and OFF at that time, plus the pulse or interval duration. For “OFF” pulses or intervals the load will switch OFF at the scheduled time, and ON at that time plus the pulse or interval duration, even if the load was not ON before the start of the “OFF” pulse or interval.

## Problem

## Solution(s)

- This timer provides an automatic 15 sec. delay between circuits 1 and 2 when programmed to switch at the same On time. Use the Interval or Pulse features to eliminate if required.

NOTE: ASTRO switching times change daily according to changing Sunrise and Sunset.

Consider fixed times with this in mind, e.g. a fixed OFF intended to end an Astro ON would be ignored if sunset moves beyond the fixed OFF time. The fixed event should be scheduled to occur outside the range of the Astro event, or an Astro Pulse should be considered.

**NOTE:** Override intervals or pulses are not ended by scheduled OFF events; they can only be ended by timing out, power interruptions, or by pressing the ON/OFF key. At the termination of an override interval or pulse, the load may be on or off. If the override interval or pulse was initiated via the front panel ON/OFF key, the load will normally be off at the end of the override interval or pulse; the load will remain on only if an ON set point has occurred during the override interval or pulse. If the override interval or pulse was initiated via the remote override connector, the circuit will revert to its normally programmed condition at the end of the override interval or pulse.

## Timer Ignores Pushbuttons

- Processor is “locked up”. Press and release RESET key while holding down the CLEAR key. Release CLEAR when “reset” appears in display. If no improvement, remove and restore AC power and battery, then re-try.

<b>Problem</b>	<b>Solution(s)</b>
<b>Difficulty in Programming</b>	<ul style="list-style-type: none"> <li>• The two most common mistakes are forgetting to press <b>AM</b> or <b>PM</b> after each time entry and forgetting to select a load with the <b>Enable</b> switch. You cannot program switch times (<b>PROGRAM</b>) unless you select a load using the <b>Enable</b> switches. Pressing the <b>HELP</b> key when an error (ERR--) message appears will explain the error and may offer recommended action.</li> </ul>
<b>Override Interval or Pulse Won't Start</b>	<ul style="list-style-type: none"> <li>• An interval or pulse duration must have been previously programmed (check by pressing <b>INTVL</b> or <b>PULSE</b> key in <b>SET</b> mode without selecting a day) and the circuit must be <b>Enabled</b>.</li> </ul>
<b>Override Interval or Pulse Won't Stop with Remote Switch</b>	<ul style="list-style-type: none"> <li>• If an interval or pulse duration has been programmed, the remote switch will only start the override interval or pulse. Operating it again will restart the override interval or pulse. the interval and pulse both must be un-programmed (Display shows dashes in review) and the circuit's slide switch must be in <b>Enable</b> position to allow remote turn off.</li> </ul>
<b>Interval Override Duration Varies</b>	<ul style="list-style-type: none"> <li>• Actual duration is the programmed duration <math>\pm 30</math> seconds.</li> </ul>

## Problem

Switch On/  
Off Display  
Doesn't  
Alternate  
During  
Programming

## Solution(s)

- After any Pulse or Interval entry, the Switch On or Switch /Off LED does not alternate, since most Pulse or Interval applications require only ON or OFF. Press **OK** without a time entry to alternate the Switch On/OFF display if required.

Some  
Switching  
Times Don't  
Show During  
Review

- All review should be done with only one circuit enabled at a time. If more than one is enabled, only events common to the circuits selected will show during review. To see all possible scheduled events, the *week long* review should be used. Events programmed via Day Group or Copy Day methods will not show when reviewing individual days or vice versa.

Difficulty in  
Programming/  
Reviewing On/  
Off Latching  
Pulse  
**or**  
Output to  
Latching  
Contactor  
Remains On  
After an Off  
Pulse

- When using pulsed output for switching a latching relay or contactor without “self-clearing” contacts, one circuit is dedicated to the load Turn On Pulse and the other to the Turn Off Pulse. The pulses are created by turning the respective circuits On momentarily (1 to 2 sec.). Therefore all events must be programmed and will review as On Pulses. The On time(s) of the controlled load will be shown as On Pulses for one circuit and the Off time(s) will review as On Pulses for the other circuit. *Note: Using the manual On/Off keys to switch this type of contactor On or Off will not provide the expected result and may cause damage to the contactor coil. For this application external Momentary Pushbutton must be added for both circuits. Refer to the Programming Examples booklet for more information.*

**NOTE:** If you need more programming assistance, request form #158ET9311, Programming Examples, which contains step-by-step instructions for several complex programs.

## ERROR MESSAGES

Pressing **HELP** when an error code is displayed will cause an error message and recommended action to scroll on display. Press any key to stop message and restore pre-error display.

- ERR 01 Too many keys pressed or **HELP** key not pressed first
- ERR 02 Numeric entry not applicable
- ERR 03 **AM - PM** key entry not applicable
- ERR 04 Clock time not setup
- ERR 05 Clock date not setup
- ERR 06 **ASTRO** not setup
- ERR 07 **HOLIDAY** not setup
- ERR 08 **OVERRIDE** not setup
- ERR 09 **ASTRO** entry not applicable
- ERR 10 **COPY** key not applicable
- ERR 11 Unable to clear a set point in week long review mode – set points may only be cleared from an individual day's program
- ERR 12 Internal calculation error – may not be recoverable – reset the time switch
- ERR 13 Day groups may not be copied to or from
- ERR 14 No **ON** or **OFF** time entry is allowed when entering an Astro Set Point
- ERR 15 A day may not be copied to itself or to a day which has already been programmed.
- ERR 16 February 29th is only permitted in leap year
- ERR 17 No circuit selected–select a circuit using the circuit enable switches
- ERR 18 Astro entry is out of limits–**SUNRISE** must be before noon and **SUNSET** must be after noon. **SUNSET** must not be within 5 hours of **SUNRISE**.

- ERR 19 The date does not agree with the previously entered day of the week—review and correct one of the entries.
- ERR 20 Holidays may not end before they start and they must end by Dec. 31.
- ERR 21 The selected holiday has already been used—Press **REVIEW** to see its definition.
- ERR 22 **HOLIDAY PROGRAM** must be cleared before clearing holiday number.
- ERR 23 Copied to days may be cleared but may not be copied or changed.
- ERR 0A **HOLIDAY** entry not applicable
- ERR 0b Override entry not applicable
- ERR 0C **PULSE** entry not applicable
- ERR 0d **INTERVAL** entry not applicable
- ERR 0E Invalid or incomplete entry
- ERR 0F Unrecognized key (or too many keys pressed)
- ERR 1A No **AM** or **PM** selection
- ERR 1b Review entry not applicable
- ERR 1C One or more of the selected circuits has a program conflict
- ERR 1d The day of the week entry does not agree with the previously entered date—the date has been cleared and you must re-enter both
- ERR 1E Out of memory
- ERR 1F Holidays may not overlap - Press **REVIEW** to identify the conflict.

**NOTE:** Error messages are subject to change with later software revisions.

## NOTES